

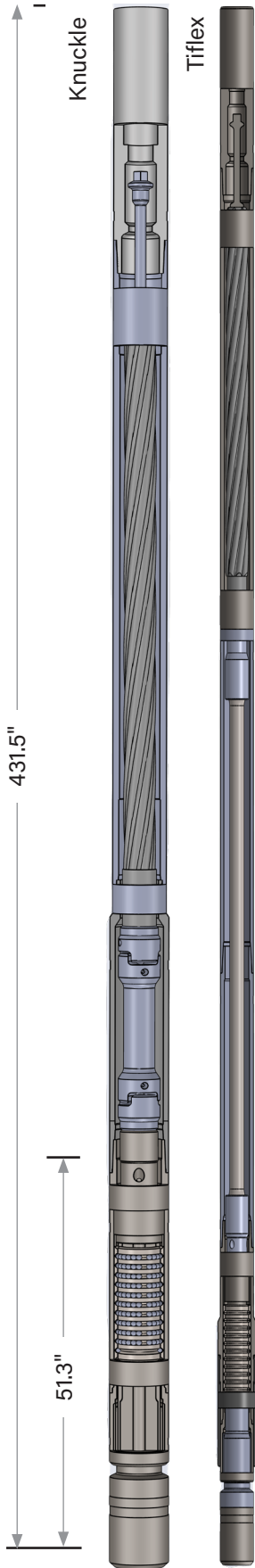

# PERFORMANCE SPEC SHEET

## 7.25" 6/7 Lobe 12.1 Stage - Fixed



### PHYSICAL DATA

Bit To Bend (in.)	51.3	Top Sub Connection	4 1/2 IF, 4 1/2 XH
Overall Length (in.)	431.5	Bit Box Connection	4 1/2 REG
Weight (lbs)	3700	Stator Length	300
		Rotor Length	293

### POWER SECTION

Flow Range	300 to 800 GPM	Stall Diff. Press. (psi)	3190
RPG	0.4 rev / gal	Stall Torque (ft-lb)	31180
Speed Range	120 to 320 RPM	Max Recommended (HP)	629
Max Diff Press. (psi)	3030		
Max. Torque (ft-lb)	19480		

### POWER SECTION FIT CHANGE

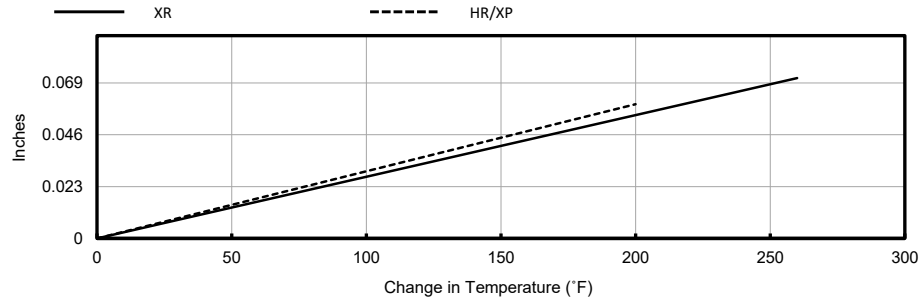

### POWER SECTIONS POWER CURVES

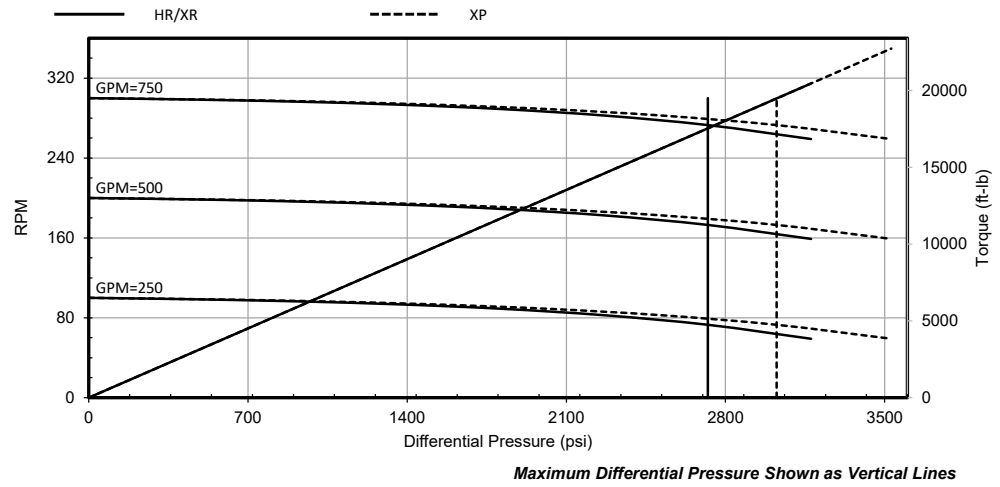

# 7.25" 6/7 Lobe 12.1 Stage - Fixed

## KNUCKLE

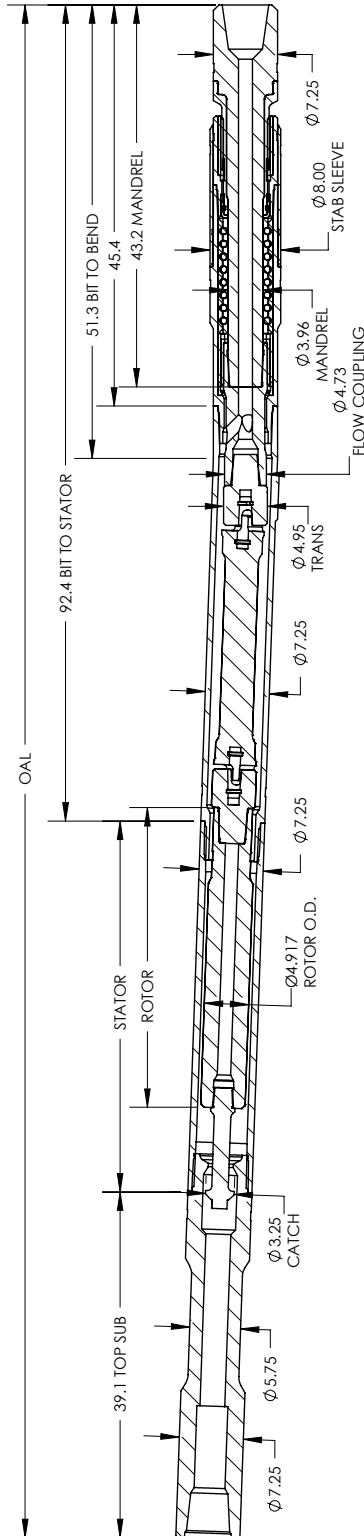

## TIFLEX

